

Vitrine 1x2x6

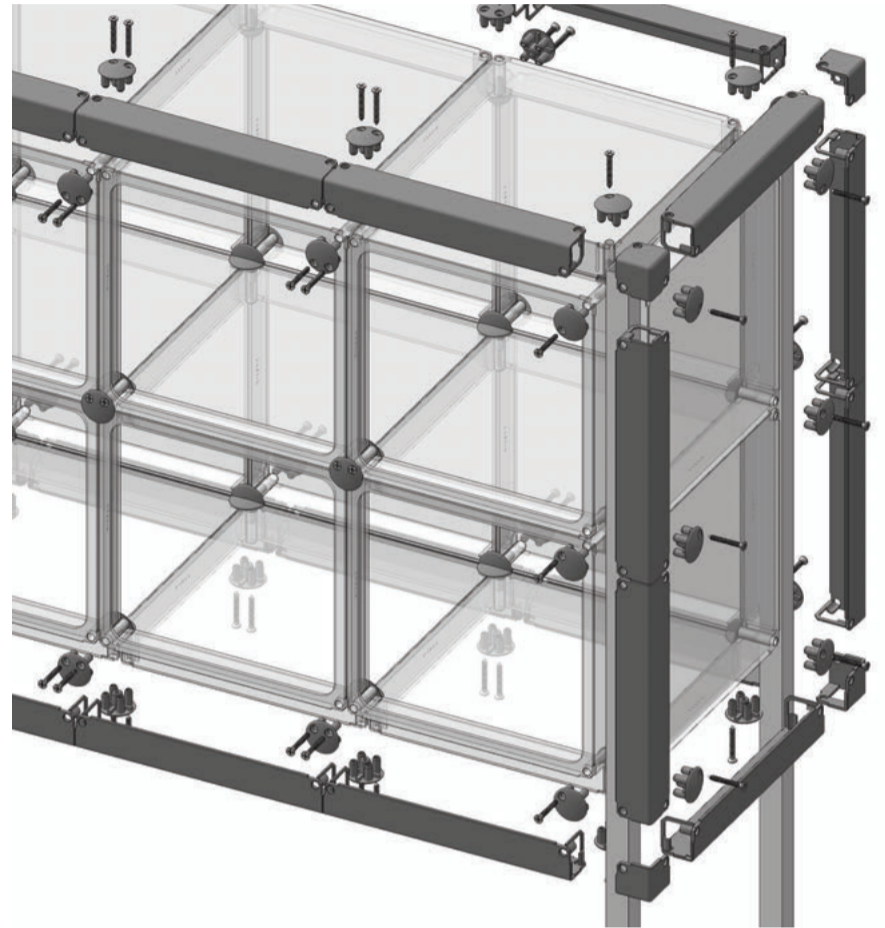

Stückliste

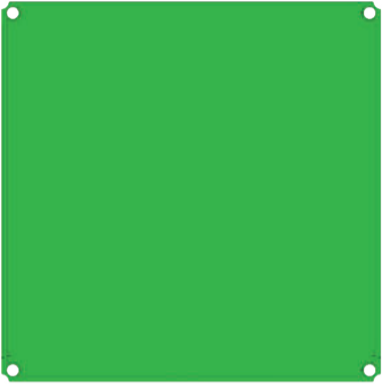
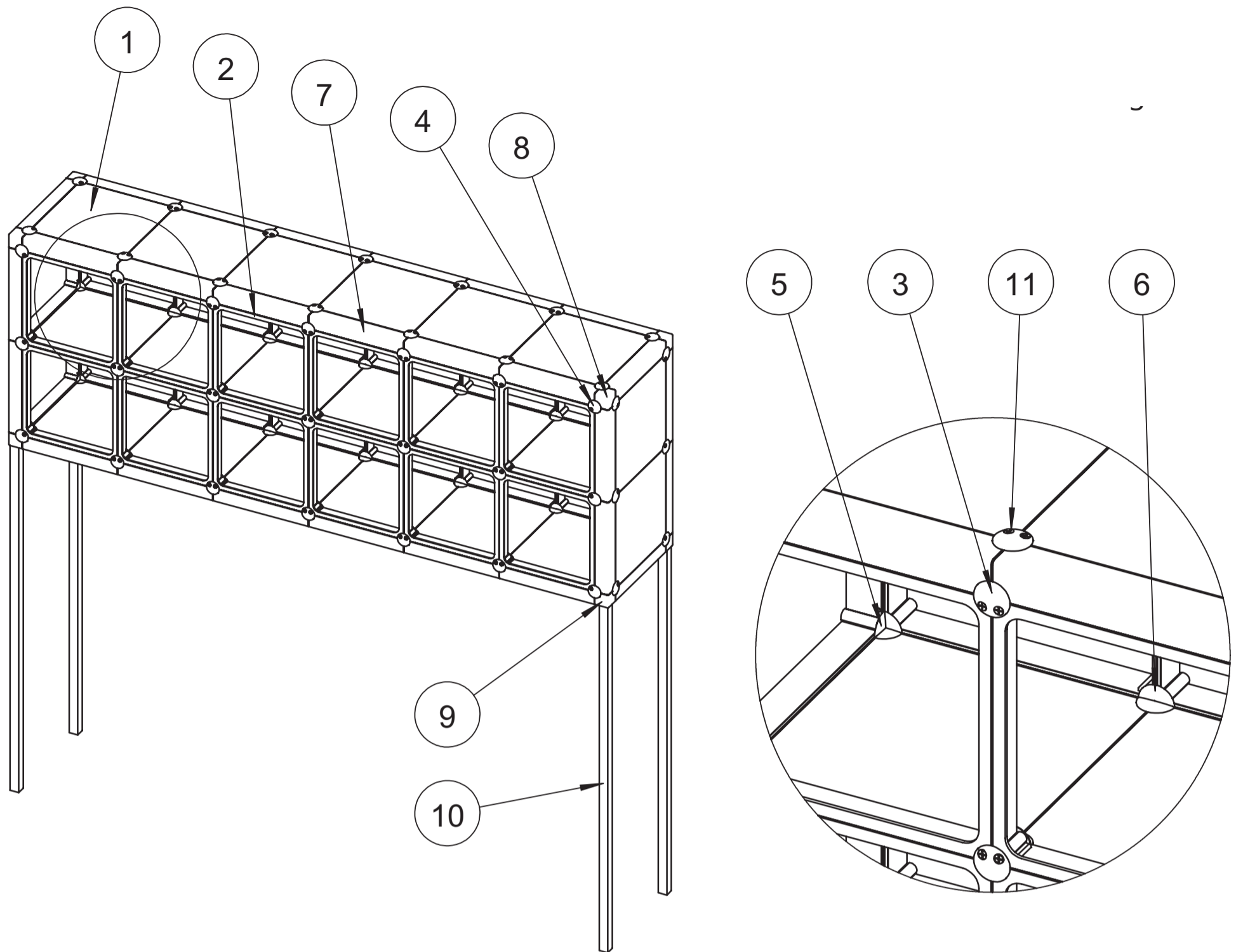

POS-NR.	BENENNUNG	ART.-NR.	MENGE	
1	Cassette	X101.04	34	
2	Cassette - Rahmen	X101.06	12	
3	Standardverbinder 2 Senkungen	X102.03	50	
4	Standardverbinder 1 Senkung	X102.04	32	
5	Innenverbinder 3-Fach	X102.13	12	
6	Innenverbinder 4-Fach	X102.14	30	
7	Eckschiene	X103.01	36	
8	Kofferecke	X103.02	4	
9	Kofferecke	X103.05	4	
10	Standfuß		4	
11	Schraube		156	

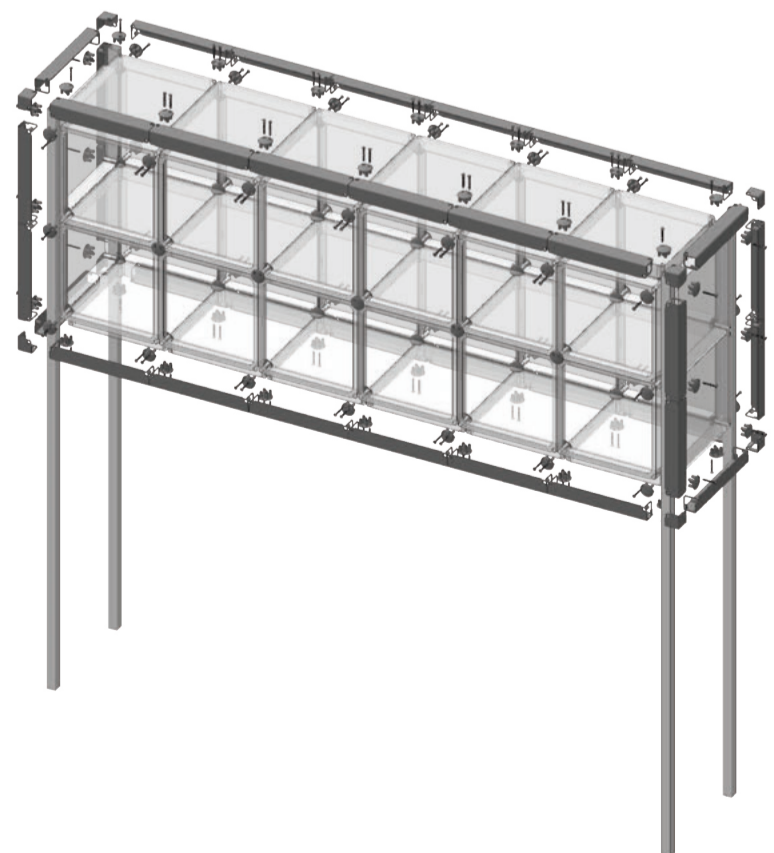
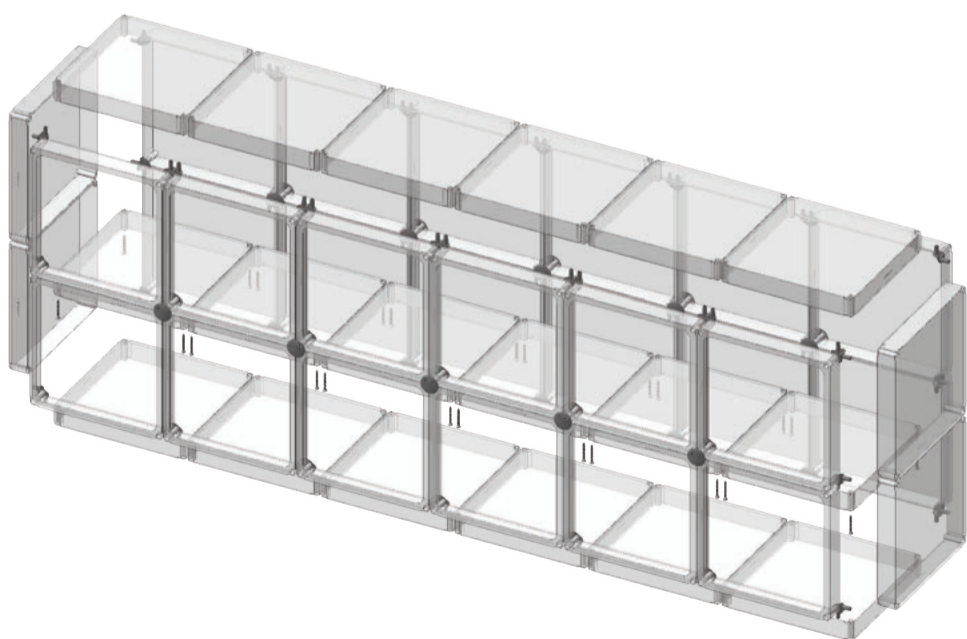
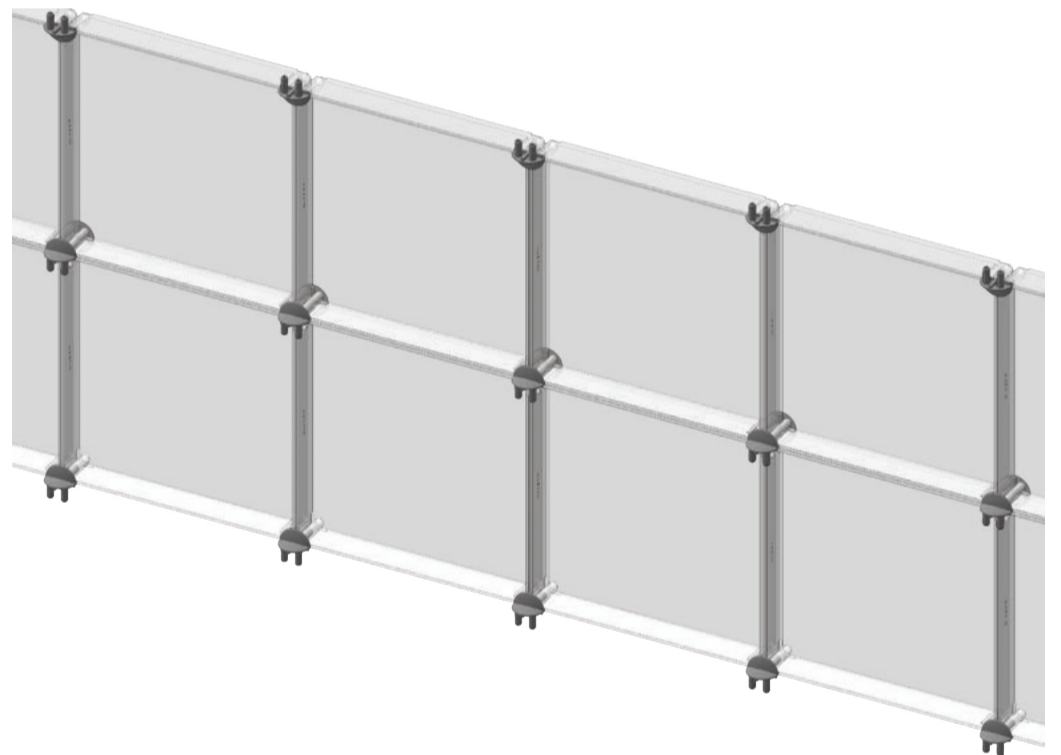
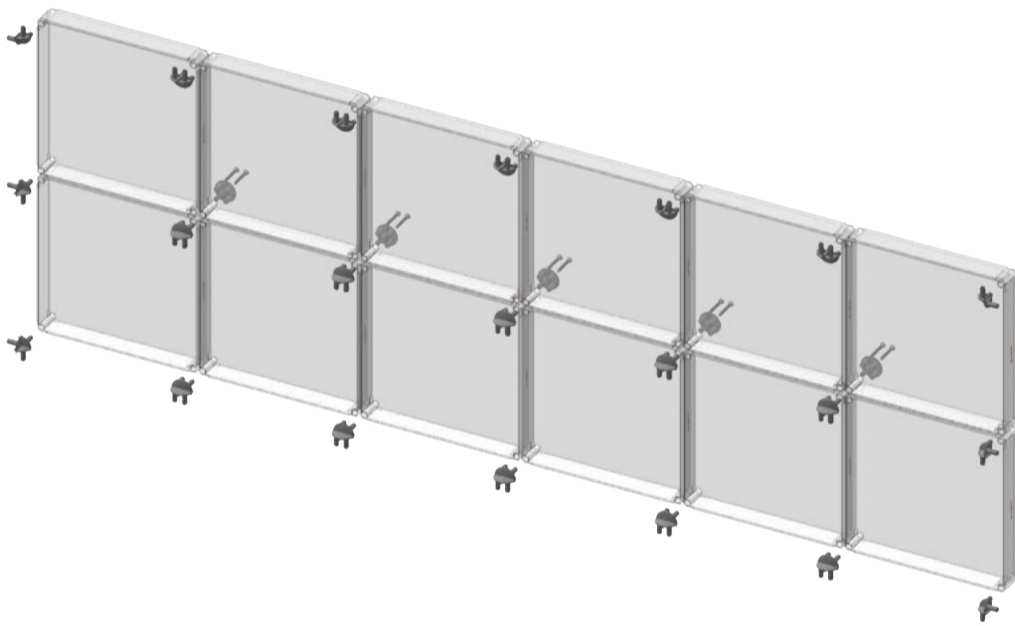
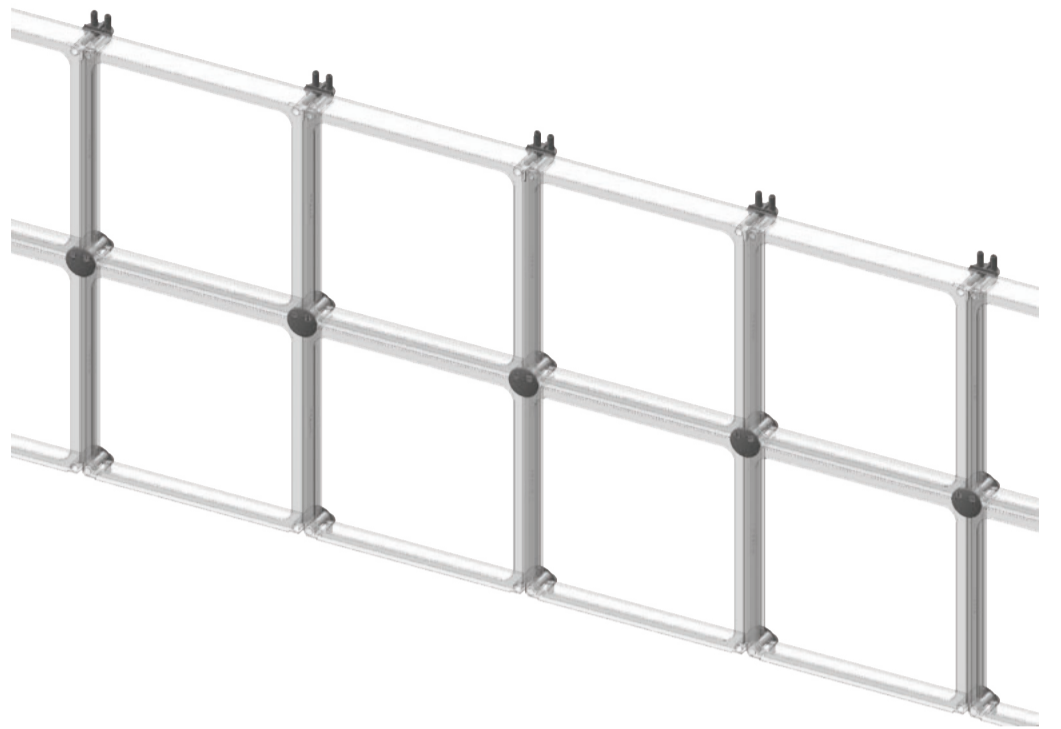
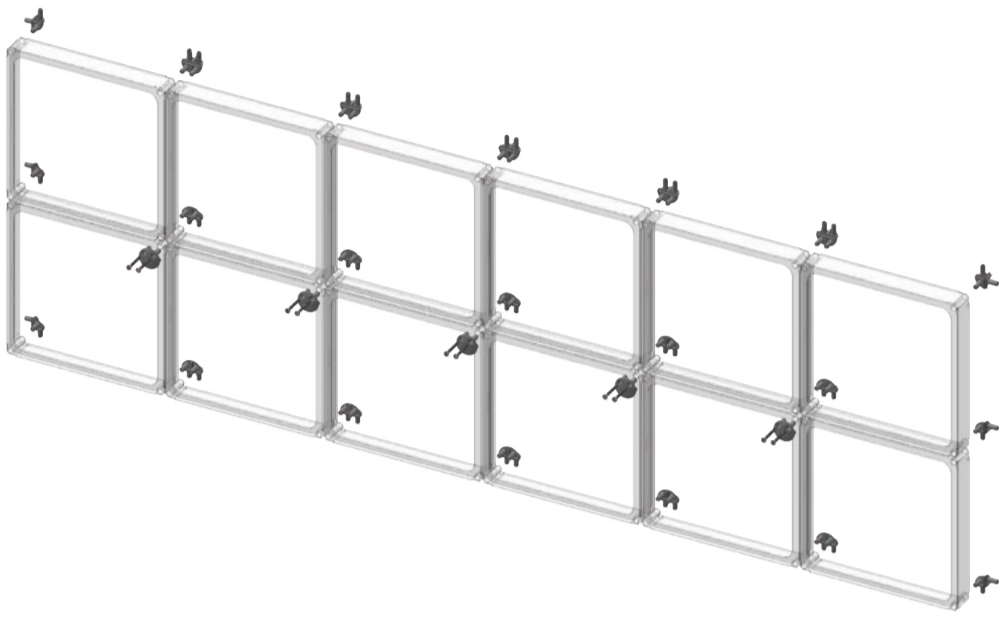

-Werkzeug
-Reinigung

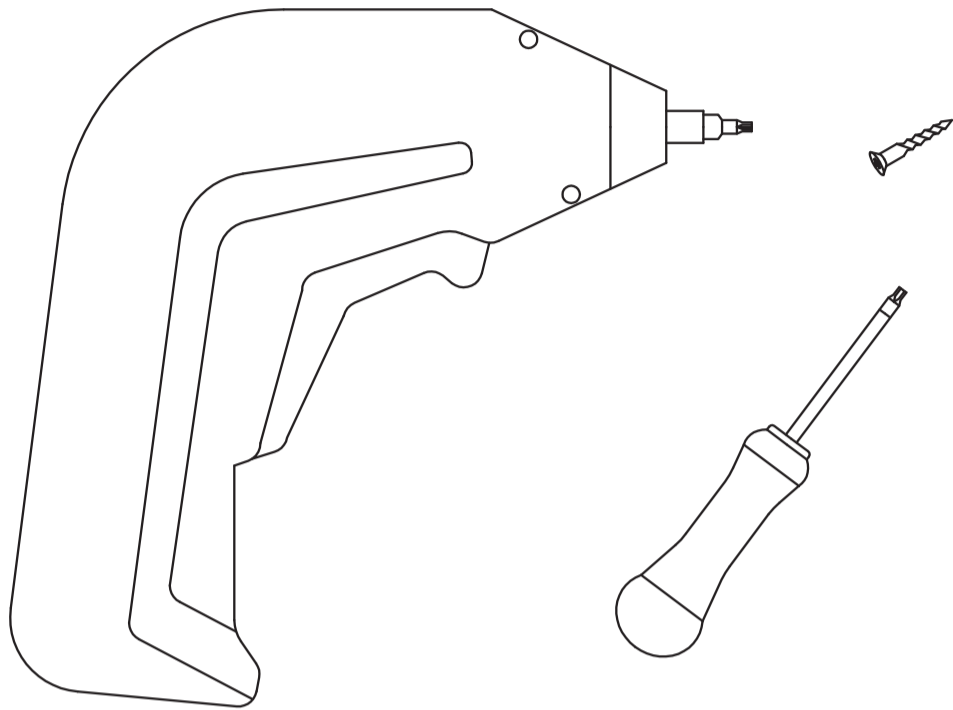

Benötigte Schrauben:
SPAX T 10 ; 3 x 25

Benötigtes Werkzeug:
Schraubendreher T 10

Maximales Drehmoment:
1 Nm

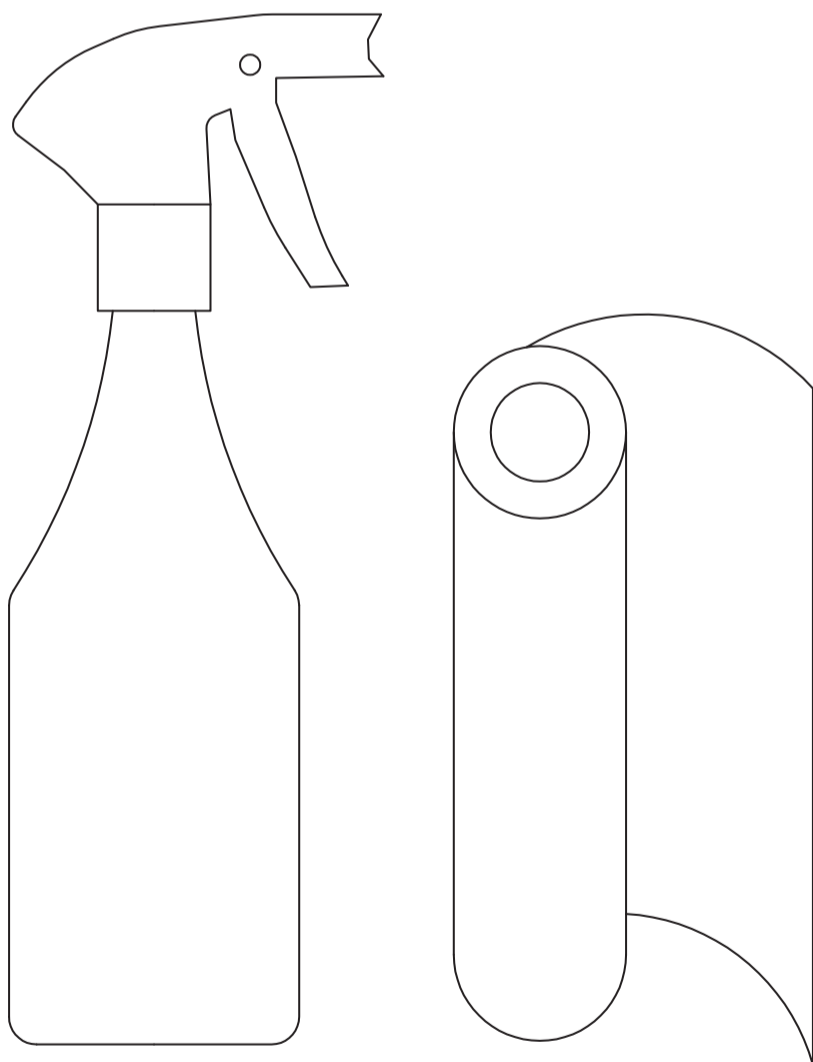

Reinigung der Systembauteile:

wie bei Autoscheinwerfern, mit
Wasser und Shampoo und einem
weichen Tuch.

xx niemals mit Lösungsmitteln xx

X-CETT Germany

Schreck Form e.K. Fon.: +49 6451 7186888 ; E-Mail: info@schreck-form.com ; www.X-Cett.com